



MPF-35 High Speed Wire Prefeeding System



■ APPLICATIONS:

The Mechtrix MPF-35 High Speed Wire Prefeeding System removes wire from reels or barrels at a uniform rate and makes it available to an automatic wire processing machine. The MPF-35 has been specifically designed and configured for use with virtually all types of automatic wire processing machines.

■ METHOD OF OPERATION:

The MPF-35 Prefeeder operating control system utilizes the Mechtrix Auto-Tune® System. These prefeeders have an integrated PLC which automatically controls all of the operating parameters of the MPF-35 so no operator speed adjustments are needed. Wire is removed from the reel or barrel by a variable speed DC drive motor and fed into the adjustable tension, vertical wire accumulation pulleys. An output encoder monitors each wire's processing characteristics, speed, length, cycle time, and dwell time as it is pulled from the accumulation pulleys by the wire processing machine. This cycle information is continuously updated allowing the speed of the MPF-35's feed motor to be continuously adjusted for smooth operation.

■ SPECIAL FEATURES:

- Variable wire back-tension system adjusts from 12oz. to 38oz. (0.34kg to 1.08kg).
- Wire de-reeling speed is continually monitored and automatically adjusted to minimize the amount of stress on the wire.
- Unique adjustable pneumatic wire dampening and shock absorbing device minimizes wire feed errors inherent in other prefeeder designs.
- Simple set-up and change-over process with retractable wire guards that make wrapping wire around pulleys fast and easy.
- Vertical design reduces floor space requirements.
- Integrated wire lifting device makes loading and un-loading of reels quick and safe (on units equipped with large reel holding device).

■ MPF-35 CONFIGURATION OPTIONS:

Wire Feed Orientation:

- MPF-35's are available in either Left-to-Right or Right-to-Left configurations.

Wire Handling Options:

- Large reel holding device with integrated reel lift mechanism
- Small reel holding device with integrated barrel feed attachment
- Both large and small reel holding devices with integrated barrel feed attachment

■ OPTIONAL ACCESSORIES:

Small Reel Holder with Integrated Barrel Feed Attachment:

- Device allows small reels 12" wide x 12" diameter (305mm wide x 305mm diameter) to be quickly mounted and changed. The device also has a retractable arm to facilitate feeding and routing wire from barrels. This unit is an add-on to machines equipped with the large reel lift mechanisms.

Mechtrix MPF-35 Wire Prefeeding System with Large Reel Lifter

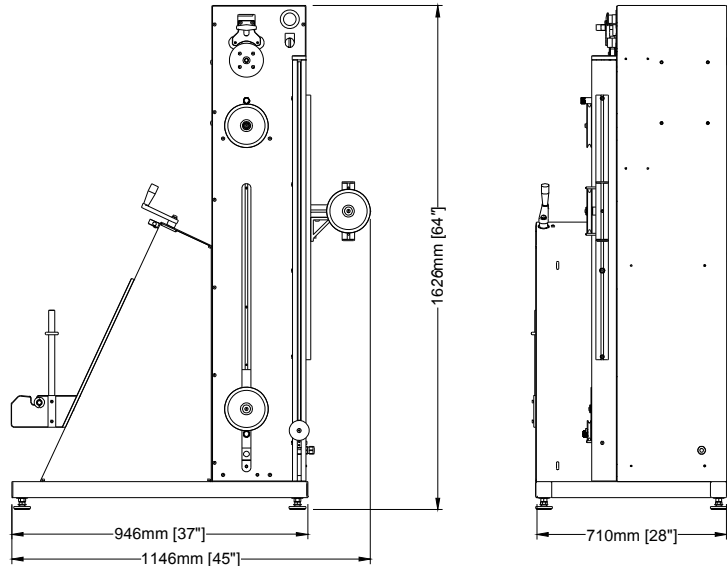

Mechtrix MPF-35 Wire Prefeeding System with Small Reel & Barrel Feed Device

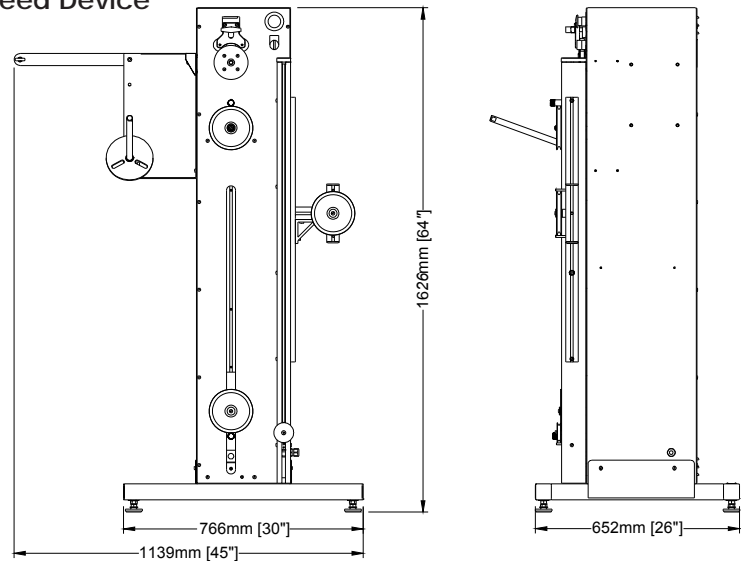

TECHNICAL DATA:

Max Wire Reel Size and Weight:

Large Reel Lifter *

- 22" wide x 34" diameter (400lbs)
- 559mm wide x 864mm diameter (180kg)

* Reel bore size and centering cones can reduce the maximum wire reel size. Machine performance may decrease significantly when running spools larger than 16" (405mm) diameter or weighing more than 100lbs (45kg).

* The MPF-35's maximum wire pulling force is 21lbs (9.5kg).

Small Reel Attachment

- 12" wide x 12" diameter (40lbs)
- 305mm wide x 305mm diameter (18kg)

Wire Draw Source Capacity:

- 40ft (12m)

Max Wire O.D:

- 3/8" (9.5mm) - Pulley Ø5" (Ø127mm)

MPF-35 Top Feed Speed:

- 23ft/sec (7m/sec)

Machine Weight:

- 251lbs (114kg)

Motor Type:

- DC-Motor

Motor Control Options:

- Integrated PLC with Auto-Tune®

Electrical Requirements:

- 115VAC, 10AMP, 60Hz
- 230VAC, 10AMP, 50Hz

Pneumatic Requirements:

- 0.24CFM@80PSI (6.8l/min@0.5Mpa)